

24" TUF-TITE RISERS (CAST IN)

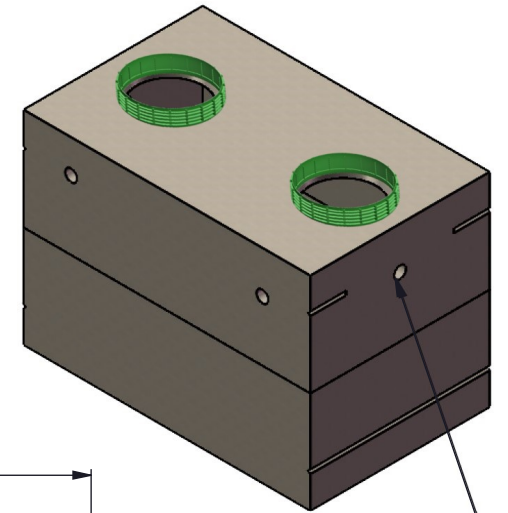

4" TUF-TITE SEALS

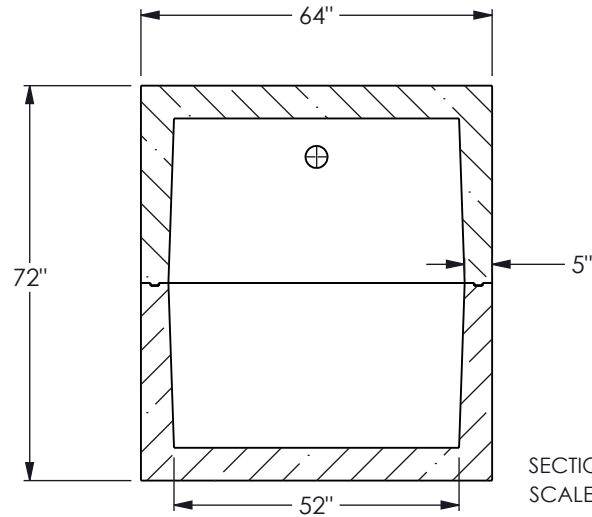

SECTION B-B
SCALE 1 : 35

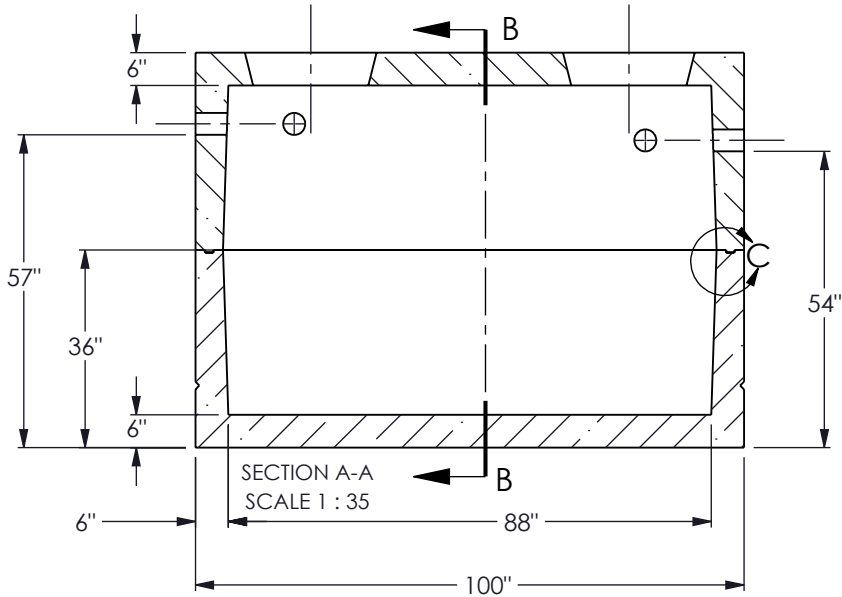

SECTION A-A
SCALE 1 : 35

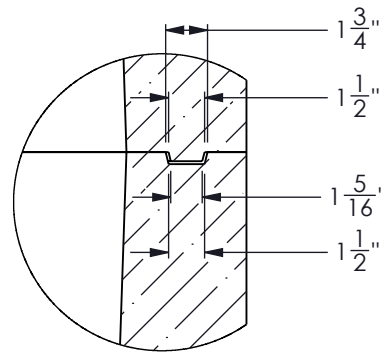

DETAIL C
SCALE 1 : 8

USI
UNDERGROUND SUPPLY INC.
82 STATE RD. WHATELY, MA 01093
413-397-3412
UNDERGROUNDSSUPPLYINC.COM

MOLD & DRAWING PRODUCED & ENGINEERED BY:
NORWALK PRECAST MOLDS INC.
P.O. Box 293 Norwalk, OH 44857
(419) 668-1639 | (800) 251-8409
sales@norwalkprecastmolds.com
www.norwalkprecastmolds.com

THIS DRAWING IS THE PROPERTY OF NORWALK PRECAST MOLDS AND MAY NOT BE COPIED OR REPRODUCED IN WHOLE OR IN PART WITHOUT WRITTEN PERMISSION FROM NORWALK PRECAST MOLDS. NORWALK PRECAST MOLDS, INC. SHALL BE INDEMNIFIED BY PURCHASER FOR ANY DESIGN FLAWS, DAMAGES OR INJURIES RESULTING FROM USE OF ANY CUSTOM PRODUCTS BUILT BY NORWALK PRECAST MOLDS, INC. PURSUANT TO THE PURCHASER'S DESCRIPTIONS OR SPECIFICATIONS.

CASTING WEIGHTS		REVISION DATE	REVISION
- TOP - APPROX. 7,280# EA.			
- BOTTOM - APPROX. 7,690# EA.			
- TOTAL - 14,970# EA.			
DRAWN BY	DATE		
CWB	11/16/22		
DESCRIPTION:	USI ITEM NUMBER:		
1000 GAL. 2PC PUMP CHAMBER HEAVY	ST1000PCH		

1,000 GALLON PUMP CHAMBER HEAVY